

Rooivalk NewCo (1)

The main contractor for the SAAF Rooivalk Attack Helicopter conducting program and contract management along with system level engineering



Rooivalk NewCo (2)

The main contractor for the SAAF Rooivalk Attack Helicopter conducting program and contract management along with system level engineering



Item	Notes/Status	Plan %	Status %	Target
1 yr Budget & 5 yr Forecast	Turnover de-risked, efficiencies identified, costs reduced	✓	✓	21 Feb 06
Ring Fence Business Operations	Ring fence for separate reporting	✓	✓	1 Apr 06
Transfer to NewCo	Due diligence process , Legal steps to transfer operations to NewCo (pending Turkey bid)	✓	0 %	Nov 06
Equity Partner	Secure equity partner	✓	0%	Apr 07

Strategic Roadmap: Denel Aviation, TMA, DPS, Astro Park

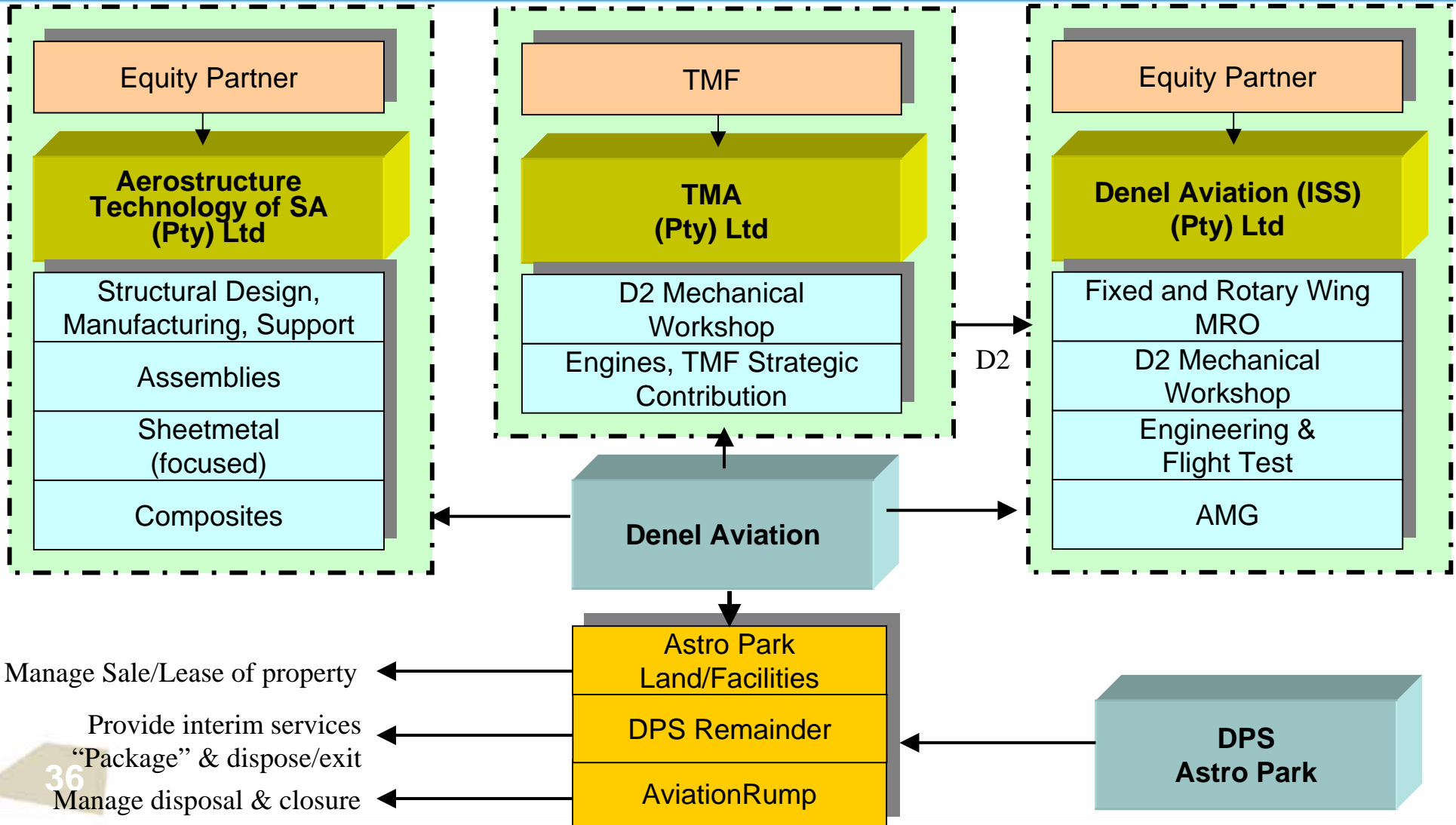

Denel Aviation (ISS) NewCo (1)

A service provider leveraging its strategic SAAF business to support the local & selected international rotary & fixed wing aircraft markets in the provision of MRO services



Rotary and Fixed Wing Aircraft
Maintenance

Denel Aviation (ISS) NewCo (2)

A service provider leveraging its strategic SAAF business to support the local & selected international rotary & fixed wing aircraft markets in the provision of MRO services



Aircraft Component Maintenance
and Engineering Support
(and Manpower Support)

Denel Aviation (ISS) NewCo (3)



A service provider leveraging its strategic SAAF business to support the local & selected international rotary & fixed wing aircraft markets in the provision of MRO services

Item	Notes/Status	Plan %	Status %	Target
1 yr Budget & 5 yr Forecast	Turnover de-risked, efficiencies identified, costs reduced	✓	✓	21 Feb 06
Ring Fence Business Operations	Ring fence for separate reporting	✓	✓	30 May 06
Reduce Overheads	Plan complete, labour notified, engaging unions	✓	90 %	31 May 06
Transfer to NewCo	Due diligence process, Legal steps to transfer operations to NewCo	✓	50 %	1 Oct 06
Equity Partner	Secure equity partner	✓	20%	Jan 07

Aerostructure Technology of SA NewCo (1)

An aerostructures facility, in cooperation with suppliers of aircraft such as Airbus and Boeing, which designs, manufactures, and assembles composites and metallic aircraft subsystem structures



**M
A
J
O
R

C
U
S
T
O
M
E
R
S**



HAWK



AIRBUS - A400M



GRIPEN



AGUSTA

Aerostructure Technology of SA NewCo (2)

An aerostructures facility, in cooperation with suppliers of aircraft such as Airbus and Boeing, which designs, manufactures, and assembles composites and metallic aircraft subsystem structures



SHEETMETAL, COMPOSITE & MACHINED PARTS

GRIPEN – REAR FUSELAGE



GRIPEN – MAIN LANDING GEAR UNIT



HAWK - FLAP

Aerostructure Technology of SA NewCo (3)

An aerostructures facility, in cooperation with suppliers of aircraft such as Airbus and Boeing, which designs, manufactures, and assembles composites and metallic aircraft subsystem structures



A400M – Wing to fuselage fairing

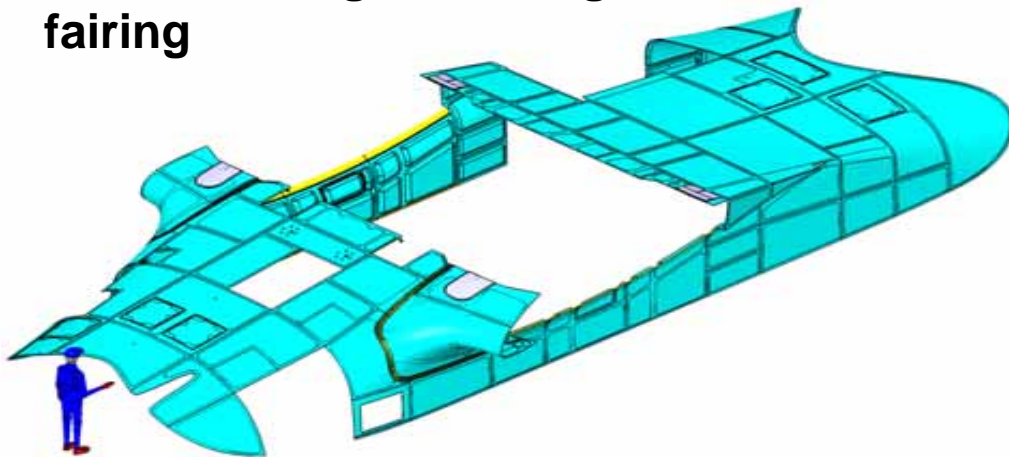

A400M- Top shell



LARGE SIZE COMPLEX STRUCTURES

Aerostructure Technology of SA NewCo (4)



An aerostructures facility, in cooperation with suppliers of aircraft such as Airbus and Boeing, which designs, manufactures, and assembles composites and metallic aircraft subsystem structures

Item	Notes/Status	Plan %	Status %	Target
1 yr Budget & 5 yr Forecast	Turnover de-risked, efficiencies identified, costs reduced	✓	✓	21 Feb 06
Ring Fence Business Operations	Ring fence for separate reporting	✓	✓	1 Apr 06
Reduce Overheads	Plan complete, labour notified, engaging unions	✓	90 %	31 May 06
Transfer to NewCo	Due diligence process , Legal steps to transfer operations to NewCo	✓	80 %	1 Aug 06
Equity Partner	Secure equity partner	✓	90%	1 Sept 06

Strategic Roadmap: Optronics

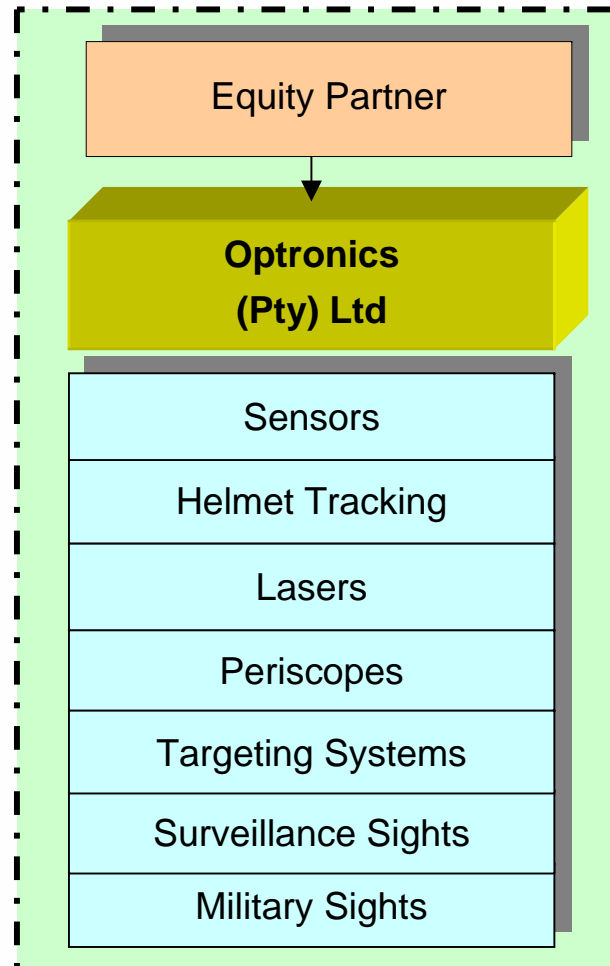

Optronic NewCo (1)

A global supplier, leveraging its expertise in Optronic products (Sensors, Helmet Tracking, Lasers, Periscopes, Targeting & Surveillance Systems & Sighting Systems)



LEO II-A1

LEO II-A3



LEO II-A5 (UltraForce II)



Goshawk 350



Argos 410-A4/Z



Argos 410-A5 (Star Q)



Argos 410-M



GPA 410



BRITE Star



Argos 550

Optronics NewCo (2)

A global supplier, leveraging its expertise in Optronics products (Sensors, Helmet Tracking, Lasers, Periscopes, Targeting & Surveillance Systems & Sighting Systems)



LH40 LRF



LP16 EYESAFE LRF



Eagle Eye



LM30 / LM40 LRF



LH40C



Periscope Systems



Kenis Thermal Imager – 3 to 5 μm

Optronics NewCo (3)

*A global supplier, leveraging its expertise in Optronics products
(Sensors, Helmet Tracking, Lasers, Periscopes, Targeting &
Surveillance Systems & Sighting Systems)*



Item	Notes/Status	Plan %	Status %	Target
1 yr Budget & 5 yr Forecast	Turnover de-risked, efficiencies identified, costs reduced	✓	✓	21 Feb 06
Ring Fence Business Operations	Ring fence for separate reporting	✓	✓	30 May 06
Reduce Overheads	Process to be initiated	80%	10 %	30 Sept 06
Transfer to NewCo	Due diligence process , Legal steps to transfer operations to NewCo	✓	20 %	1 Sept 06
Equity Partner	Secure equity partner	✓	40%	Oct 06

Strategic Roadmap: Munitions

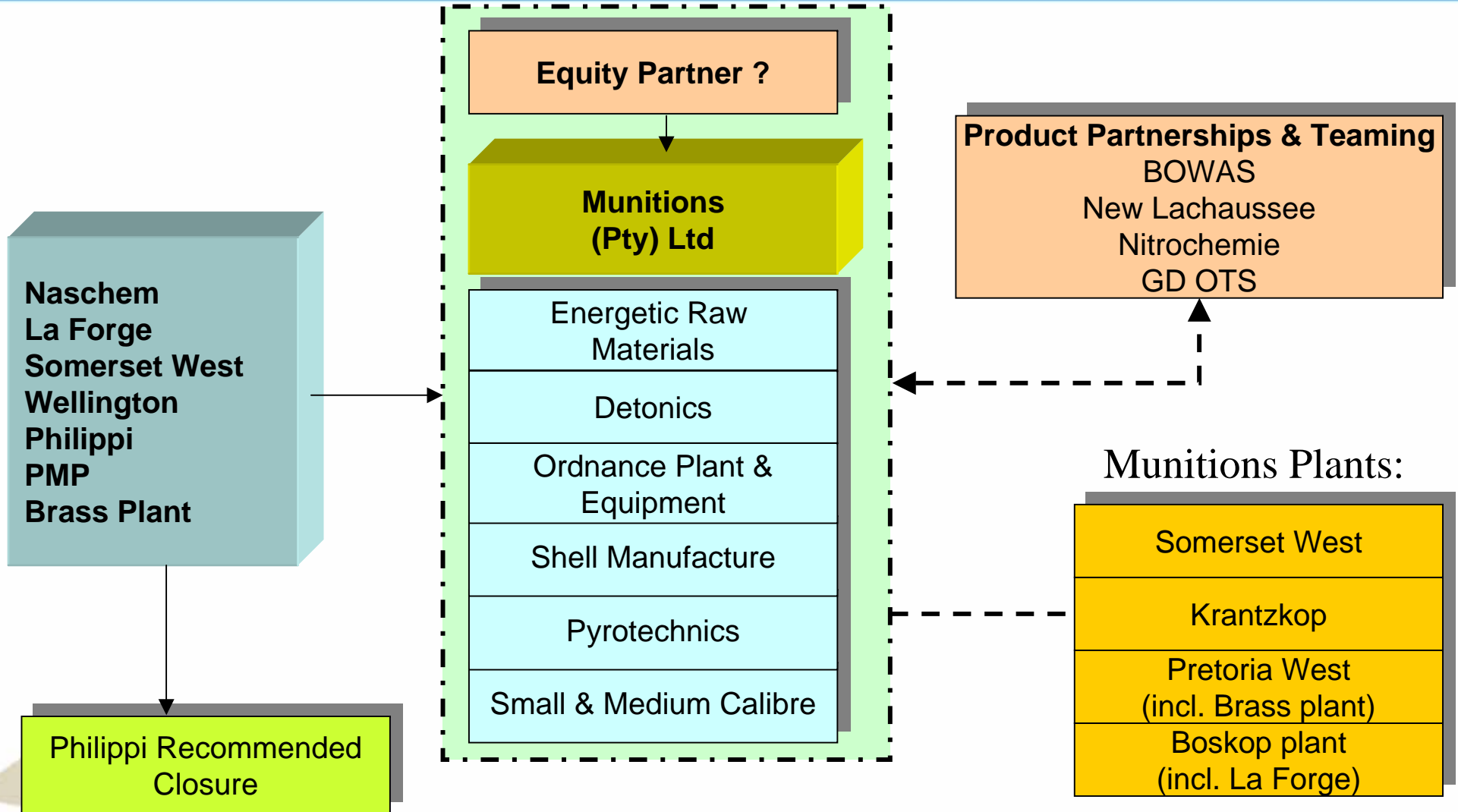

Munitions NewCo (1)

An integrated supplier of selected munitions (artillery ammunition, mortars, bombs, large & medium calibre ammunition pyrotechnics; missile motors & warheads) to local & international customers



ARTILLERY PROPULSION

ROCKET & MISSILES SUBSYSTEMS



PROPELLANTS FOR SMALL CALIBRE & POWER CARTRIDGES

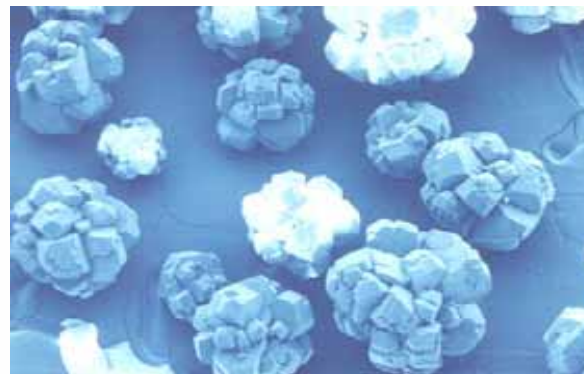

ENERGETIC RAW MATERIALS FOR MILITARY & CIVILIAN APPLICATION



POWER CARTRIDGES

Munitions NewCo (2)

An integrated supplier of selected munitions (artillery ammunition, mortars, bombs, large & medium calibre ammunition pyrotechnics; missile motors & warheads) to local & international customers



ARTILLERY AMMUNITION



ARMOUR AMMUNITION



AIRCRAFT BOMBS



**Medium Calibre
Ammunition**



Sporting Ammunition



**RIOT CONTROL
PRODUCTS**

Munitions NewCo (3)

Denel Munitions Strategy



- Initial strategy required consolidation of operations to one or two sites
- Consolidation and relocation study completed
- Relocation to single site is costly (up to R2 Billion)
- Manufacturing processes are interdependent “*all or nothing*” and have downstream implications for Munitions and Denel Dynamics (motors, warheads)
- Overheads are high due to replicated management
- Operational efficiencies can be improved with updated plant and improved processes
- Munitions should be a sustainable business at minimum turnover of R1.15 Billion p/a and with cost cutting
- Strategy therefore to continue operations at four explosive sites with consolidated management
- Implement tight controls with annual review of sustainability of Munitions business

Munitions NewCo (4)

An integrated supplier of selected munitions (artillery ammunition, mortars, bombs, large & medium calibre ammunition pyrotechnics; missile motors & warheads) to local & international customers



Item	Notes/Status	Plan %	Status %	Target
1 yr Budget & 5 yr Forecast	2006/07 Budget remains as per Plan. Update next 4 yrs	✓	50 %	31 May 06
Ring Fence Business Operations	Ring fence for separate reporting	✓	✓	1 Apr 06
Reduce Overheads	Operations and management plan for NewCo	50%	5%	31 Aug 06
Transfer to NewCo	Due diligence process , Legal steps to transfer operations to NewCo	0%	0%	1 Apr 07
Equity Partner	Secure equity partner	0%	0%	1 Apr 07

Strategic Roadmap Denel Land Systems

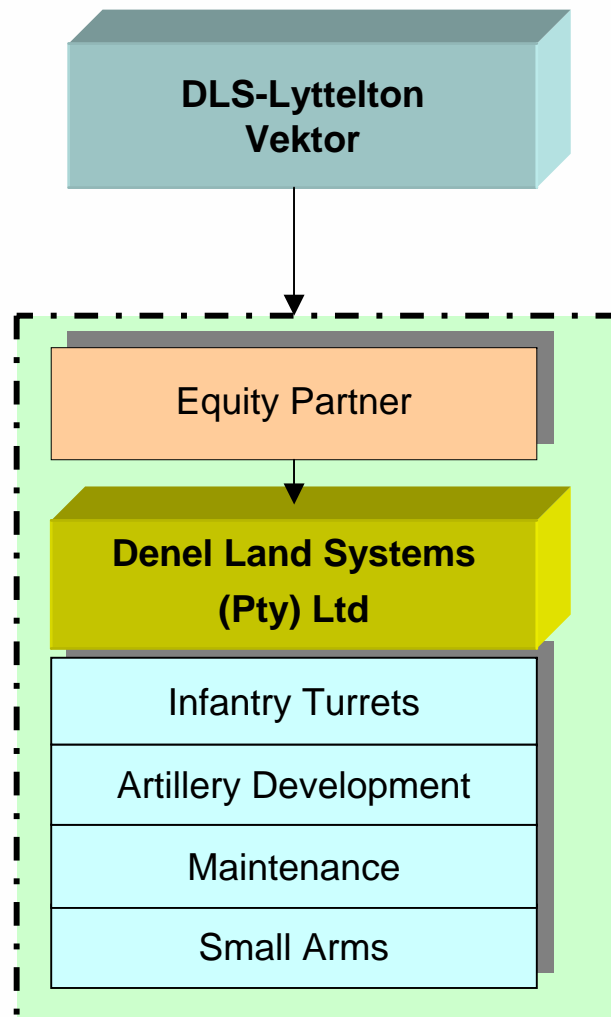

Denel Land Systems (DLS) NewCo (1)



Denel Land Systems is a consolidated, project based design & development house for Combat Turrets, Artillery Development, Maintenance and Upgrades and Small Arms



MCV Infantry Fighting System

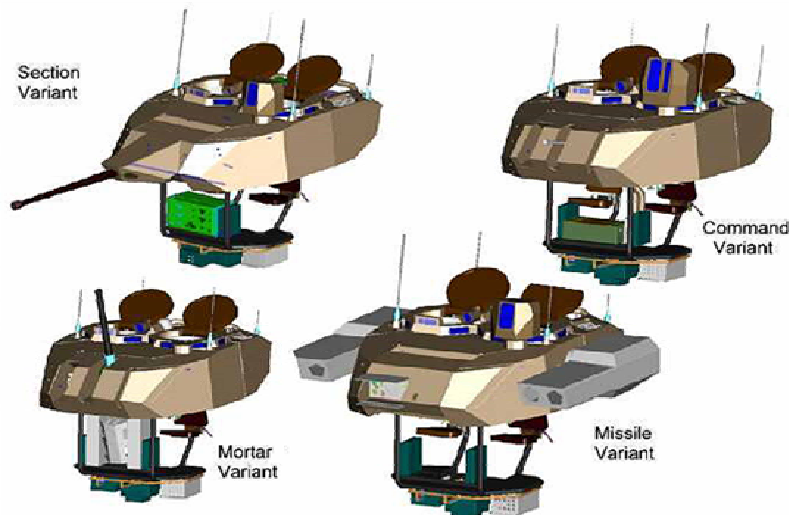

Acrobat 81mm Mortar Fighting System

Denel Land Systems (DLS) NewCo (2)



Denel Land Systems is a consolidated, project based design & development house for Combat Turrets, Artillery Development, Maintenance and Upgrades and Small Arms



**155mm 45 Calibre G6 SP
Howitzer System**



**155mm 45 Calibre G5 Towed
Howitzer System**



**155mm 52 Calibre G6T6 SP
Howitzer System**



**155mm 52 Calibre G5-2000
Towed Howitzer System**



**155mm 52 Calibre G5-2000
Towed Howitzer System**



**105mm 52 Calibre LEO Light
Towed Howitzer System**

Denel Land Systems (DLS) NewCo (3)



Denel Land Systems is a consolidated, project based design & development house for Combat Turrets, Artillery Development, Maintenance and Upgrades and Small Arms

Item	Notes/Status	Plan %	Status %	Target
1 yr Budget & 5 yr Forecast	Turnover de-risked, efficiencies identified, costs reduced. Hoefyster contract NB!	✓	✓	21 Feb 06
Ring Fence Business Operations	Ring fence for separate reporting	✓	✓	1 Apr 06
Reduce Overheads	Completed	✓	✓	Dec 05
Transfer to NewCo	Due diligence process , Legal steps to transfer operations to NewCo	✓	50 %	1 Sept 06
Equity Partner	Secure equity partner	✓	20 %	Jan 07

Strategic Roadmap Mechem

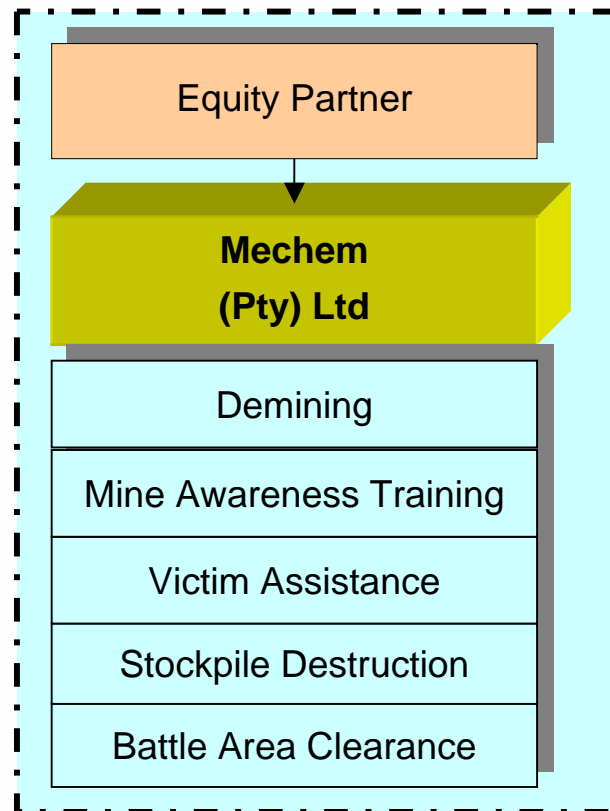

Mechem NewCo (1)

Mechem is a global leader in cost effective mine action, including demining, mine awareness training, victim assistance, stockpile destruction, clearance of battle areas & unexploded ordnance



Mechem NewCo (2)

Mechem is a global leader in cost effective mine action, including demining, mine awareness training, victim assistance, stockpile destruction, clearance of battle areas & unexploded ordnance



Item	Notes/Status	Plan %	Status %	Target
1 yr Budget & 5 yr Forecast	Minimal changes.	✓	✓	21 Feb 06
Ring Fence Business Operations	Ring fence for separate reporting	✓	✓	1 Apr 06
Transfer to NewCo	Due diligence process , Legal steps to transfer operations to NewCo	✓	40 %	1 Aug 06
Equity Partner	Secure equity partner	✓	5 %	Jan 07

Denel Holdings (Pty) Ltd

**Aerostructures
(Pty) Ltd**

An aerostructures facility, in cooperation with suppliers of aircraft such as Airbus and Boeing, which designs, manufactures, and assembles composites and metallic aircraft subsystem structures

**Denel Aviation
(ISS)
(Pty) Ltd**

A service provider leveraging its strategic SAAF business to support the local & selected international rotary & fixed wing aircraft markets in the provision of MRO services

**Dynamics
(Pty) Ltd**

A niche global competitor and local technology provider in the areas of tactical missiles, guided weapons and UAV systems

**TMA
(Pty) Ltd**

TMA's focus is to be the centre of excellence for manufacturing and product support of selected; gears and shafts; gearbox casings; and engines and gearbox assemblies

**Mechem
(Pty) Ltd**

Mechem is a global leader in cost effective mine action, including demining, mine awareness training, victim assistance, stockpile destruction, clearance of battle areas & unexploded ordnance

**Optronics
(Pty) Ltd**

A global supplier, leveraging its expertise in Optronics products (Sensors, Helmet Tracking, Lasers, Periscopes, Targeting & Surveillance Systems & Sighting Systems)

**Denel Land
Systems
(Pty) Ltd**

Denel Land Systems is a consolidated, project based design & development house for Combat Turrets, Artillery Development, Maintenance and Upgrades and Small Arms

**Munitions
(Pty) Ltd**

Denel Munitions is an integrated supplier of selected munitions (artillery ammunition, mortars, bombs, large & medium calibre ammunition pyrotechnics; missile motors & warheads) to local & international customers

**Rooivalk
(Pty) Ltd**

The main contractor for the SAAF Rooivalk Attack Helicopter conducting program and contract management along with system level engineering

**Command &
Control
(Pty) Ltd**

A local main contractor for integrated level 5 air defence systems, and a specialized local and international supplier of C3 products with GBADS as flagship program

Agenda



- Key Events
- Overview of the Global Defence Industry & Denel
- Strategy Imperatives
- Recapitalisation
- Strategy Implementation Process & Status

Transformation

- Head Office Developments & Changes
- Non-Core Disposal

Transformation & People



Objective: Organisational Effectiveness

Transform our people into a motivated, innovative and empowered workforce with a commercial and performance-based mindset within a truly representative and diverse environment

Diversity

- Race
- Gender
- Age
- Disability

Skills Retention & Development

- Technical career paths
- Leadership development
- Succession planning
- Motivated personnel

Culture

- Performance culture
- Commercial mindset
- Diversity tolerance

Process

- Situation analysis (internal situation vs external benchmarks and criteria)
- Identify transformation goals & objectives
- Formulate & implement action plan to address shortcomings within an aggressive timeframe

Agenda



- Key Events
- Overview of the Global Defence Industry & Denel
- Strategy Imperatives
- Recapitalisation
- Strategy Implementation Process & Status
- Transformation

Head Office Developments & Changes

- Non-Core Disposal

Head Office Developments & Changes



- Convert and align accounting standards with International Financial Reporting Standards (IFRS)
- Contracted Internal Audit function and Risk Management to PwC to ensure alignment with best practice
- Pension fund – currently healthy, showing good returns, tax efficient and forces employees to save for retirement. Denel to retain current fund arrangements.
- Umed – closed medical scheme with ageing members. Investigating a transition to an open scheme involving amalgamation with another scheme over medium term.

Agenda



- Key Events
- Overview of the Global Defence Industry & Denel
- Strategy Imperatives
- Recapitalisation
- Strategy Implementation Process & Status
- Transformation
- Head Office Developments & Changes

Non-Core Disposal

Status on Non Core Asset Disposal



Entity	Share-holding	Expected date of completion	Current status
Ariviakom (Pty) Ltd	22.98%	Completed 27 Feb 2006	Completed
SPP (Pty) Ltd	100%	End June 2006	Recommendation to Board on 3 May 2006
Irenco (Observer)	Business unit	End May 2006	Contract signed on 27 February 2006
Voltco	Business unit	Completed	Contract signed. Payment received 18 April 2006
Bonaero Park (Pty) Ltd	100%	30 June 2006	Contract signed on 31 March 2006. Competition Comm application filed 18 April 2006
Dendustri	Division	End Feb 2006	Payment for business received 28 Feb 2006. Transfer of related properties in process
Cosource (Pty) Ltd	51,7%	End June 2006	Revised transaction presented to Board/Minister. Board risk review on exit from Cosource 3 May 06. PFMA approval outstanding
Irenco Plastics (Pty) Ltd	100%	Nov 2005	Completed Only retention money received on 4 April 2006
65 TOTAL			

Thank you

